



# Armor Inox Services

Our Global Solutions & Specialized Services



-  Studies
-  Installations
-  Controls
-  Commissioning
-  Hotline
-  Spare Parts Dept.
-  Maintenance
-  Expertise & Performance
-  Line efficiency . Optimizations
-  Training

#### TECHNICAL SUPPORT

Mon.-Fri. : 1:00 am - 11:00 am CST  
Phone +332 9722 6222  
hotline@armorinox.com

#### EMERGENCY CALL CENTER

Available 24h a day on your dedicated line.  
Phone +33 972 168 860  
For subscribers of Gold or Platinum contracts.

#### SPARE PARTS DEPARTMENT

Phone +332 9722 6340  
spareparts@armorinox.com

# HOTLINE

Best-in-class recognized proactivity ||

**Armor Inox's engineers and technicians are trained on the latest technologies and can assist with the best in class expertise to achieve highest performance.**



## HOTLINE TECHNICAL SUPPORT

### A local service

Our technicians are at your disposal to resolve the challenges you will share with them. We take our pride in successfully assisting you get the maximum out of your Armor Inox equipment.



### Standard hours technical support

Monday to Friday : 1:00 am to 11:00 am CST.

Please contact us by email [hotline@armorinox.com](mailto:hotline@armorinox.com) or Phone +332 9722 6222.

**For additional support, please subscribe to our Hotline Contracts, and call us using your Contract Number on your dedicated line +33 972 168 860.**

### Hotline Contracts :

- BASIC** Monday to Saturday : 1 am to 11 am CST. / 8 am to 6 pm FR.
- SILVER** Monday to Friday : 12 am to 3 pm CST. / Saturday : 1 am to 11 am CST.  
Monday to Friday : 7 am to 10 pm FR. / Saturday : 8 am to 18 am FR.
- GOLD** 24h/24 from Monday to Saturday.
- PLATINIUM** 24h/24 / 7 days a week / 362 days a year.

**NEW!**

## Video Remote Assist

### New videoconferencing solution

Armor inox combines proximity and performance to always be by your side and efficiently support you during a technical assistance mission.

Technicians can connect with you from wherever they are located. Remote Assist using your internet browser on your mobile devices is now available for a simplified video assistance. No installation required.



[www.amaxperteye.com](http://www.amaxperteye.com)

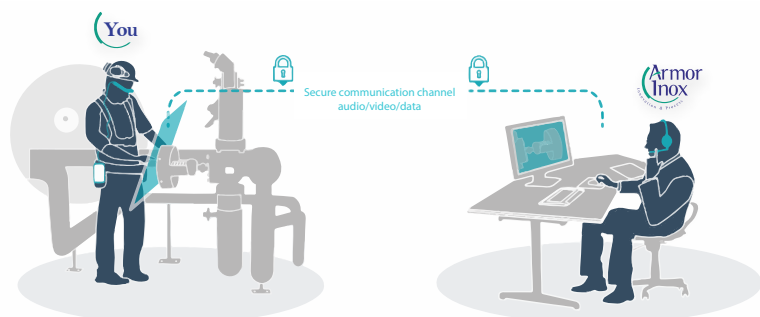

# ASSISTANCE

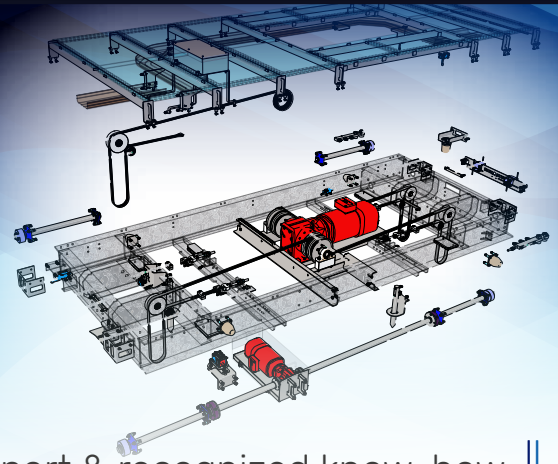

Support & recognized know-how ||

**Armor Inox provides the best level of support and service so your equipment is used in the best conditions for maximum productivity and longevity**



## Our objective

### SPARE PARTS



New service dedicated to the purchase of spare parts online is now available on Armor Inox's website. You will find the recommended spare parts lists for your machines.



Easy to use this site will save you time to identify your needs and order. Our spare parts lists, depending on the degree of urgency, allows you to optimize a lot of critical parts in your site and help you prepare your maintenance operations.



We inform you of necessary retrofits needs.

Your spare parts orders are processed quickly and shipped worldwide using the appropriate means of delivery.

### MAINTENANCE



Diagnostics with latest communication technologies, rapid availability of spare parts with quick on-site interventions, are key to the very high standard we use when servicing you.

## Year-round service

- Pre defined frequency inspection and suggestion/replacement of parts
- Equipment monitoring with a proposed preventive maintenance schedule planned for the year
- Remote analysis of connected machines with diagnostic equipment (preventive - predictive)

Our interventions on site or in our technical center allows minimizing down time and getting the most out of your line.



## CONTACT US

### TECHNICAL SUPPORT

Mon.-Fri. : 1:00 am - 11:00 am CST  
Phone +332 9722 6222  
hotline@armorinox.com

### EMERGENCY CALL CENTER

Available 24h a day on your dedicated line.  
Phone +33 972 168 860  
For subscribers of **Gold** or **Platinum** contracts.

### SPARE PARTS DEPARTMENT

Phone +332 9722 6340  
spareparts@armorinox.com

# EXPERTISE

Experience & recognized skills ||

**With Armor Inox you benefit from the best level of expertise and know-how on the line we designed.**

## EXPERTISE & PERFORMANCE



From the study to the commissioning of the installation, we always care about your concerns and deadlines.

### Our experience and skills allow us to propose :



A machine safety audit pointing out key items that need attention or modifications.



Personalized tank validation (consistency) and probe calibration.



IT audit (hardware, state / quality of the network, memory space, obsolescence).



Updated electrical diagrams & manuals.



Global performance report of the line offering proposed solutions to increase its use and throughput.



3D exploded views development for each sub equipments you have that could facilitate the maintenance.

## OPTIMIZATION



Our team follows such equipment with multiple customers and will inform you of the necessary changes or upgrades to be implemented to have your equipment exceed the standard.

### ARMOR INOX proposes,

Upgrading to standard, latest improvements, line performance validation...

## CONTACT US

### TECHNICAL SUPPORT

Mon.-Fri. : 1:00 am - 11:00 am CST  
Phone **+332 9722 6222**  
hotline@armorinox.com

### EMERGENCY CALL CENTER

Available 24h a day on your dedicated line.  
Phone **+33 972 168 860**  
For subscribers of **Gold** or **Platinum** contracts.

### SPARE PARTS DEPARTMENT

Phone **+332 9722 6340**  
spareparts@armorinox.com

# TRAINING

Knowledge & maximum performance ||

**We combine availability and experience with our service commitment to ensure your performance & success.**

## TRAINING



**Our team is dedicated to train you**

**(Maintenance . Electrical . Automation . Mechanics . Production scheduling)**

Following start up, we offer refresher training for your staff. Targeted technical training on specific equipment (drives, robots, network), replacement of components ... With fully developed training materials such as tutorials e-learning...

Armor Inox provides the best level of support and service so that your equipment is part of your team's DNA.

Multiple programs can be custom defined with you for 1 shot or multiple repeat training combining theoretical explanations and practical hands-on experiences.

Please contact :

### TECHNICAL SUPPORT

Phone +332 9722 6222

hotline@armorinox.com

### SPARE PARTS DEPARTMENT

Phone +332 9722 6340

spareparts@armorinox.com



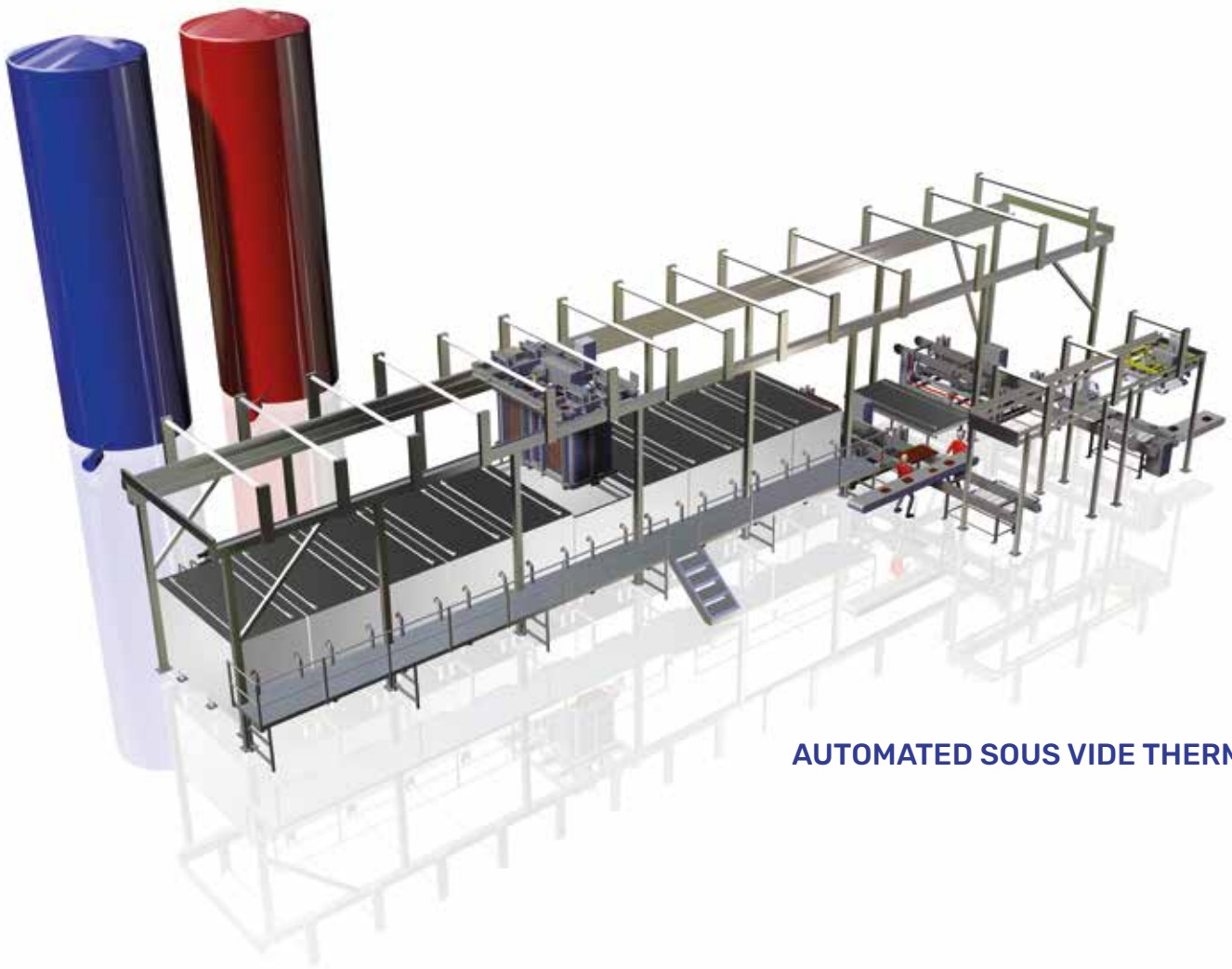

## AUTOMATED SOUS VIDE THERMIX™

### TECHNICAL SUPPORT

Mon.-Fri. : 1:00 am - 11:00 am CST ||  
Phone **+332 9722 6222**  
hotline@armorinox.com

### EMERGENCY CALL CENTER

Available 24h a day on your dedicated line.  
Phone **+33 972 168 860**  
For subscribers of **Gold** or **Platinum** contracts.

### SPARE PARTS DEPARTMENT

Phone **+332 9722 6340**  
spareparts@armorinox.com



Parc d'Activités de Brocéliande  
F-56430 Mauron - France  
**+33 (0)297 22 62 63**  
**www.armorinox.com**

